

UCX 00 Inserts

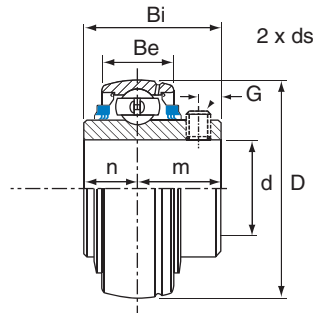

**UCX 00 Inserts with Set Screws (Medium Duty)**

Bearing Unit	Shaft Dia.		D	Bi	Be	n	m	G	ds		Load Rating (kg)		Weight kg
	d inch	d mm							inch	mm	Dynamic	Static	
UCX05	1"	25	62	38.1	19	15.9	22.2	5	1/4" - 28UNF	M6 x 0.75	1520	1020	0.39
UCX05-16		0.38											
UCX06	1.1/4"	30	72	42.9	20	17.5	25.4	6.5	1/4" - 28UNF	M6 x 0.75	2010	1390	0.58
UCX06-20		0.55											
UCX07	1.1/4"	35	80	49.2	22	19.0	30.2	8.0	5/16" - 24UNF	M8 x 1.0	2560	1810	0.72
UCX07-20													0.75
UCX07-22	1.3/8"								5/16" - 24UNF				0.72
UCX08	1.1/2"	40	85	49.2	22	19.0	30.2	8.0	5/16" - 24UNF	M8 x 1.0	2650	1910	0.83
UCX08-24		0.87											
UCX09	1.3/4"	45	90	51.6	24	19.0	32.6	10.0	5/16" - 24UNF	M8 x 1.0	2750	2020	0.95
UCX09-28		0.97											
UCX10	2"	50	100	55.6	25	22.2	33.4	10.0	3/8" - 24UNF	M10x1.25	3400	2550	1.29
UCX10-32		1.26											
UCX11	2.1/4"	55	110	65.1	27	25.4	39.7	10.0	3/8" - 24UNF	M10x1.25	4100	3150	1.80
UCX11-36		1.70											
UCX12	2.3/8"	60	120	65.1	30	25.4	39.7	10.0	3/8" - 24UNF	M10x1.25	4480	3470	2.05
UCX12-38		2.03											
UCX13	2.1/2"	65	125	74.6	30	30.2	44.4	12.0	3/8" - 24UNF	M10x1.25	4870	3810	2.52
UCX13-40		2.61											
UCX14	2.3/4"	70	130	77.8	32	33.3	44.5	12.0	7/16" - 20UNF	M12x1.50	5190	4190	2.74
UCX14-44		2.75											
UCX15	3"	75	140	82.6	33	33.3	49.3	12.0	7/16" - 20UNF	M12x1.50	5700	4550	3.41
UCX15-48		3.32											

**Bearing Speeds**

The maximum rotational speed of a grease lubricated ball bearing is related to the fit between shaft and bearing.

Under normal operating conditions the fit between the bearing and shaft should be h7. The maximum permissible bearing speeds are shown on the right.

A looser fit, allowing lower speeds is recommended for lighter loads and a tighter fit allowing higher speeds is recommended for heavier loads

Bearing No.	Max Speed rev/min	Bearing No.	Max Speed rev/min
201	4500	210	1800
202	4500	211	1600
203	4500	212	1500
204	4000	213	1400
205	3400	214	1300
206	2800	215	1200
207	2400	216	1100
208	2200	217	1000
209	1900	218	950